

MAXI JOLLY HV BILEVEL

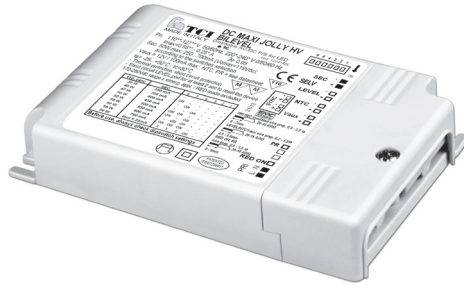

Direct current dimmable electronic drivers with DIP-SWITCH
Alimentatori elettronici regolabili in corrente continua con DIP-SWITCH



Accessories not supplied - Accessori non a corredo		
Article - Articolo	L (length)	Code - Codice
Synchronization cable Cavetto di sincronizzazione	1,5 m / 4 ft	485720512
	4 m / 13 ft	485720513
	50 cm / 19,68"	485720515
	20 cm / 7,87"	485720516

3.1.7

Dimmable multipower DIP-SWITCH drivers - Compact case - BILEVEL
Alimentatori multipotenza regolabili con DIP-SWITCH - Formato compatto - BILEVEL



Rated Voltage
Tensione Nominale
110 ÷ 127 V⁽²⁾
220 ÷ 240 V

Frequency
Frequenza
50/60 Hz

AC Operation range
Tensione di utilizzo AC
99 ÷ 264 V

DC Operation range
Tensione di utilizzo DC
(see page info15)
DC 176 ÷ 280 V
(NO reduction mode)

Article Articolo	Code Codice	P out W	V out DC ⁽¹⁾	I out DC	V out max.	ta °C	tc °C	λ Power Factor	η max. Efficiency ⁽¹⁾
DC MAXI JOLLY HV BILEVEL	122414BL	30 (30 ⁽²⁾)	2...112	250 mA cost	119	-25...+50	90	0,95 ⁽³⁾	> 89
		34 (34 ⁽²⁾)	2...112	300 mA cost					
DC MAXI JOLLY HV BILEVEL N	122414BLN	40 (40 ⁽²⁾)	2...112	350 mA cost					
		47 (40 ⁽²⁾)	2...112	400 mA cost					
		50 (40 ⁽²⁾)	2...110	450 mA cost.					
		50 (40 ⁽²⁾)	2...100	500 mA cost.					
		50 (40 ⁽²⁾)	2...91	550 mA cost.					
		50 (40 ⁽²⁾)	2...83	600 mA cost.					
		50 (40 ⁽²⁾)	2...83	650 mA cost.					
50 (40 ⁽²⁾)	2...70	700 mA cost.							

⁽¹⁾ Referred to $V_{in} = 230$ V, 100% load - Riferito a $V_{in} = 230$ V, carico 100%
⁽³⁾ Pout ≥ 25 W

Wiring diagram - Schema di collegamento
(Max. LED distance at page info8 - Massima distanza LED a pagina info8)

Power
Potenza
3 ÷ 50 W



Weight - Peso:
gr. 210 / 7,4 oz.
Pcs - Pezzi 50

Compatible with ZHAGA (AM3)

Output current ripple
≤ 3%⁽¹⁾

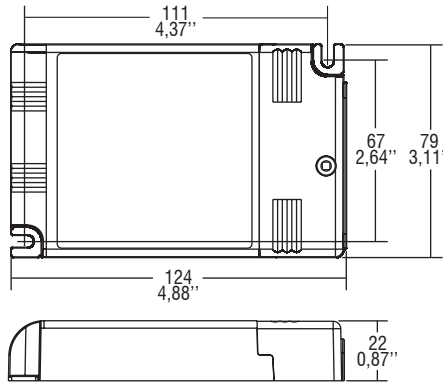

Reference Norms
Norme di riferimento
EN 50172 (VDE 0108)
EN 55015
EN 61000-3-2
EN 61000-3-3
EN 61347-1
EN 61347-2-13
EN 61547
EN 62384

Max. pcs for CB B16A
(see page info17)
15 pcs

In rush current
20A 400μsec

Features

- IP20 independent driver.
- Class II protection against electric shock for direct or indirect contact.
- Active Power Factor Corrector.
- Analogical input for thermal sensor connection.
- Auxiliary output 12 V max. 100 mA.
- Current regulation ± 5 % including temperature variations.
- Input and output terminal blocks on the same side (wire cross-section up to 2,5 mm² / AWG13).
- Clamping screws on primary and secondary circuits for cables with diameter: min. 3 mm - max. 8 mm.
- Protections:
 - against overheating and short circuits;
 - against mains voltage spikes;
 - against overloads.

Caratteristiche

- Alimentatore indipendente IP20.
- Protetto in classe II contro le scosse elettriche per contatti diretti e indiretti.
- PFC attivo.
- Entrata analogica per connessione sensore termico.
- Uscita ausiliare 12 V max. 100 mA.
- Corrente regolata ± 5 % include variazioni di temperatura.
- Morsetti di entrata e uscita sullo stesso lato (sezione morsetto 2,5 mm² / AWG13).
- Serracavo su primario e secondario per cavi di diametro: min. 3 mm - max. 8 mm.
- Protezioni:
 - termica e cortocircuito;
 - contro le extra-tensioni di rete;
 - contro i sovraccarichi.

