

Direct current electronic drivers with DIP-SWITCH
Alimentatori elettronici in corrente continua con DIP-SWITCH

Made in Italy

constant CURRENT constant VOLTAGE



MP 32 HV K2

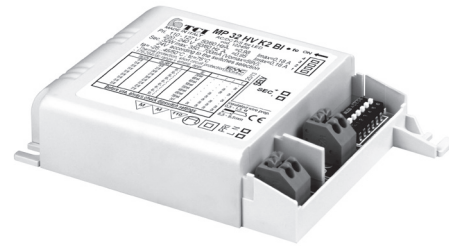

MP 32 HV BI



2.1

Multipower drivers - Compact case - Not dimmable
 Alimentatori multipotenza - Formato compatto - Non regolabili

Rated Voltage
Tensione Nominale

110 ÷ 127 V ⁽²⁾
 220 ÷ 240 V

Frequency
Frequenza

50-60 Hz

AC Operation range
Tensione di utilizzo AC

100 ÷ 264 V

DC Operation range
Tensione di utilizzo DC

(see page info15)
 170 ÷ 280 V

Power - Potenza

1 ÷ 32 W

iTHD

≤ 15% ⁽¹⁾

Output current ripple

≤ 3% ⁽¹⁾

Standards compliance

EN 55015
 EN 61000-3-2
 EN 61000-3-3
 EN 61347-1
 EN 61347-2-13
 EN 61547

Max. pcs for CB B16A

(see page info17)
 50 pcs

In rush current

5A 50μsec

Article Articolo	Code Codice	P out W	V out DC ⁽¹⁾	I out DC	U out V	ta °C	tc °C	λ max. Power Factor	η max. Efficiency ⁽¹⁾	
MP 32 HV K2 ⁽⁴⁾	122202	Constant current output - Uscita in corrente costante				59	-25...+45 ⁽³⁾ /50	75	0,98	> 88 %
		19 (15 ⁽²⁾)	2...54	350 mA cost.						
MP 32 HV BI	122456	22 (15 ⁽²⁾)	2...54	400 mA cost.						
		24 (15 ⁽²⁾)	2...54	450 mA cost.						
		27 (15 ⁽²⁾)	2...54	500 mA cost.						
		30 ⁽³⁾ (15 ⁽²⁾)	2...54	550 mA cost.						
		32 ⁽³⁾ (15 ⁽²⁾)	2...53	600 mA cost.						
		32 ⁽³⁾ (15 ⁽²⁾)	2...49	650 mA cost.						
		32 ⁽³⁾ (15 ⁽²⁾)	2...46	700 mA cost.						
		Constant voltage output - Uscita in tensione costante								
		17 (15 ⁽²⁾)	24 cost.	1050 mA max.	-					

⁽¹⁾ Referred to V_{in} = 230 V, 100% load - Riferito a V_{in} = 230 V, carico 100%

⁽²⁾ 122202BIS: order code for BIS marked product - codice di ordine per il prodotto marchiato BIS

Light output level in DC operation: Factory default 100% E0Fi=1

Livello di emissione luminosa in funzionamento DC: Impostazioni di fabbrica 100% E0Fi=1

Features

- Multipower driver supplied with dip-switch for the selection of the output current.
- IP20 independent driver, for indoor use (MP 32 HV K2).
- Class II protection against electric shock for direct or indirect contact (MP 32 HV K2).
- Driver for built-in use (MP 32 HV BI).
- It can be used for lighting equipment in protection class I and II (MP 32 HV BI).
- Active Power Factor Corrector.
- Current regulation ±5 % including temperature variations.
- Supplied with terminal cover and cable retainer.
- Input and output terminal blocks on the same side (wire cross-section up to 1,5 mm² / AWG15).
- Clamping screws on primary and secondary circuits for cables with diameter: min. 3 mm - max. 8 mm (MP 32 HV K2).
- Driver can be secured with slot for screws.
- Protections:
 - against overheating and short circuits;
 - against mains voltage spikes;
 - against overloads.
- Thermal protection = C.5.a.

Caratteristiche

- Alimentatore multipotenza fornito di dip-switch per la selezione della corrente in uscita.
- Alimentatore indipendente IP20, per uso interno (MP 32 HV K2).
- Protetto in classe II contro le scosse elettriche per contatti diretti e indiretti (MP 32 HV K2).
- Alimentatore da incorporare (MP 32 HV BI).
- Utilizzabile per apparecchi di illuminazione in classe di protezione I e II (MP 32 HV BI).
- PFC attivo.
- Corrente regolata ±5 % incluse variazioni di temperatura.
- Fornito di coprimorsetto e serracavo.
- Morsetti di entrata e uscita sullo stesso lato (sezione cavo fino a 1,5 mm² / AWG15).
- Serracavo su primario e secondario per cavi di diametro: min. 3 mm - max. 8 mm (MP 32 HV K2).
- Fissaggio dell'alimentatore tramite asole per viti.
- Protezioni:
 - termica e cortocircuito;
 - contro le extra-tensioni di rete;
 - contro i sovraccarichi.
- Protezione termica = C.5.a.



Direct current electronic drivers with DIP-SWITCH
Alimentatori elettronici in corrente continua con DIP-SWITCH

Made in Italy

IP 20 **SCREW FIXING** $\varnothing 72$ 2.83" Weight - Peso gr. 120 / 4,2 oz.
 Pcs - Pezzi 50

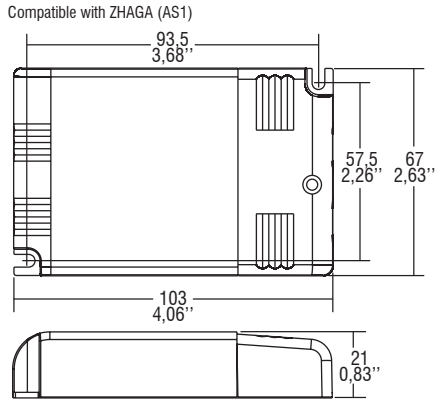

BUILT-IN **SCREW FIXING** Weight - Peso gr. 115 / 4,1 oz.
 Pcs - Pezzi 50

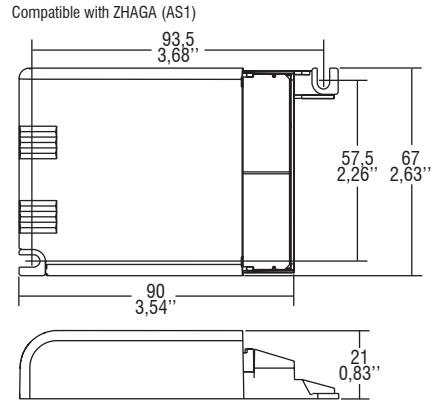

Wiring diagram - Schema di collegamento (Max. LED distance on page info8 - Massima distanza LED a pagina info8)

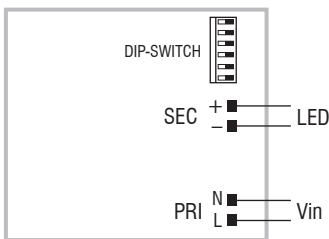

2.1
 Multipower drivers - Compact case - Not dimmable
 Alimentatori multipotenza - Formato compatto - Non regolabili