

MAXI JOLLY SV WR 50 - 1...10 V & PUSH

Direct current dimmable electronic drivers with DIP-SWITCH
Alimentatori elettronici regolabili in corrente continua con DIP-SWITCH

Made in Italy 

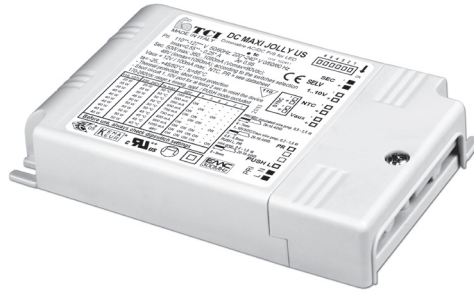

Rated Voltage
Tensione Nominale
110 ÷ 127 V ⁽²⁾
220 ÷ 277 V

Frequency
Frequenza
50-60 Hz

AC Operation range
Tensione di utilizzo AC
99 ÷ 305 V

DC Operation range
Tensione di utilizzo DC
(see page info15)
DC 170 ÷ 276 V
(NO PUSH mode function)

Power - Potenza
3 ÷ 50 W

iTHD
≤ 10% ⁽¹⁾

Stand by power
≤ 0,5 W

Output current ripple
≤ 3% ⁽¹⁾

Standards compliance
CSA-C22.2 n° 107.1 ⁽²⁾
CSA-C22.2 n° 250.13 ⁽²⁾
EN 50172 (VDE 0108)
EN 55015

EN 61000-3-2
EN 61000-3-3
EN 61347-1
EN 61347-2-13
EN 61547
EN 62384
UL 1012 ⁽²⁾
UL 8750 ⁽²⁾

Max. pcs for CB B16A
(see page info17)
30 pcs

In rush current
10A 200µsec

Article Articolo	Code Codice	Dimming type	P out W	V out DC ⁽¹⁾	I out DC	U out V	ta °C	tc °C	λ max. Power Factor	η max. Efficiency ⁽¹⁾
DC MAXI JOLLY SV WR	151510	AM	18,5 (18,5 ⁽²⁾)	10...53	350 mA cost.	60	-25...+50	90	0,96 ⁽⁶⁾	> 92
			21 (21 ⁽²⁾)	10...53	400 mA cost.					
			23,5 (23,5 ⁽²⁾)	10...53	450 mA cost.					
			26,5 (26,5 ⁽²⁾)	10...53	500 mA cost.					
			29 (29 ⁽²⁾)	10...53	550 mA cost.					
			31,5 (31,5 ⁽²⁾)	10...53	600 mA cost.					
			34,5 (34,5 ⁽²⁾)	10...53	650 mA cost.					
			37 (37 ⁽²⁾)	10...53	700 mA cost.					
			39,5 (39,5 ⁽²⁾)	10...53	750 mA cost.					
			42 (42 ⁽²⁾)	10...53	800 mA cost.					
			45 (45 ⁽²⁾)	10...53	850 mA cost.					
			47,5 (47,5 ⁽²⁾)	10...53	900 mA cost.					
			50 (40 ⁽²⁾)	10...52	950 mA cost.					
			50 (40 ⁽²⁾)	10...50	1 A cost.					
			50 (40 ⁽²⁾)	10...48	1,05 A cost.					
50 (40 ⁽²⁾)	10...45	1,1 A cost.								
50 (40 ⁽²⁾)	10...43	1,15 A cost.								
50 (40 ⁽²⁾)	10...41	1,2 A cost.								

⁽¹⁾ Referred to V_m = 230 V, 100% load - Riferito a V_m = 230 V, carico 100%

⁽⁶⁾ λ=0,9 C Pout > 21 W @230 V
λ=0,96 C @110 V

Accessories not supplied - Accessori non a corredo		
Article - Articolo	L (length)	Code - Codice
REG 1-10 V (12.3)		123999L
WIRELESS INTERFACES (W.)		-

277 V input voltage drivers - Dimmable
Alimentatori per rete 277 V - Regolabili

9.3

Features

- Multipower driver supplied with dip-switch for the selection of the output current.
- IP20 independent driver, for indoor use.
- Class II protection against electric shock for direct or indirect contact.
- Active Power Factor Corrector.
- Analogical input (NTC) for thermal sensor connection.
- Auxiliary output 12 V max. 100 mA.
- Current regulation ±5 % including temperature variations.
- Input and output terminal blocks on the same side (wire cross-section up to 2,5 mm² / AWG13).
- Clamping screws on primary and secondary circuits for cables with diameter: min. 3 mm - max. 8 mm.
- Protections:
 - against overheating and short circuits;
 - against mains voltage spikes;
 - against overloads.
- Thermal protection = C.5.a.





Caratteristiche

- Alimentatore multipotenza fornito di dip-switch per la selezione della corrente in uscita.
- Alimentatore indipendente IP20, per uso interno.
- Protetto in classe II contro le scosse elettriche per contatti diretti e indiretti.
- PFC attivo.
- Entrata analogica (NTC) per connessione sensore termico.
- Uscita ausiliare 12 V max. 100 mA.
- Corrente regolata ±5 % incluse variazioni di temperatura.
- Morsetti di entrata e uscita sullo stesso lato (sezione cavo fino a 2,5 mm² / AWG13).
- Serracavo su primario e secondario per cavi di diametro: min. 3 mm - max. 8 mm.
- Protezioni:
 - termica e cortocircuito;
 - contro le extra-tensioni di rete;
 - contro i sovraccarichi.
- Protezione termica = C.5.a.



MAXI JOLLY SV WR 50 - 1...10 V & PUSH

Direct current dimmable electronic drivers with DIP-SWITCH
Alimentatori elettronici regolabili in corrente continua con DIP-SWITCH

 **IP 20**  **SCREW FIXING**  Ø84 3,31"  Weight - Peso gr. 215 / 7,6 oz. Pcs - Pezzi 50

Compatible with ZHAGA (AM3)

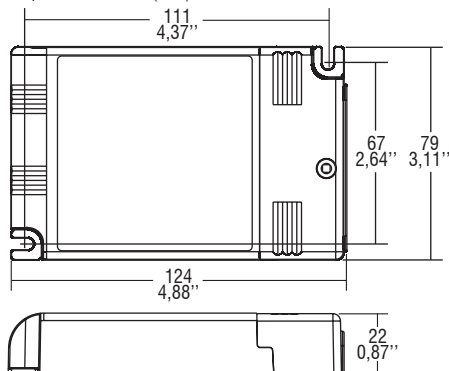

Wiring diagram - Schema di collegamento (Max. LED distance on page info8 - Massima distanza LED a pagina info8)

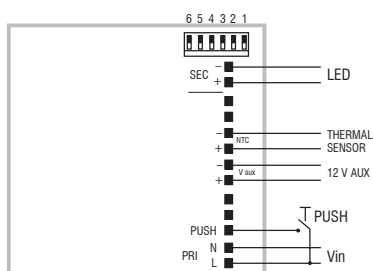

PUSH diagram - Collegamento PUSH

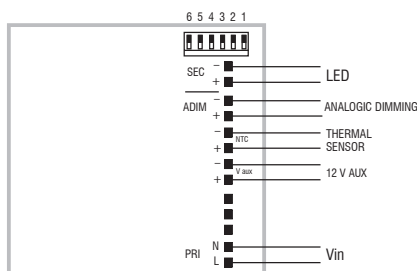

ADIM diagram - Collegamento ADIM

Operation Mode

- Light regulation 0/1 - 100 % by means of PUSH function, 0/1...10 V local interface (I=1 mA) or 100 Kohm potentiometer.
- **Full AM DIMMING: 1-100%.**
- Light regulation 0/1 - 100 % by means of PUSH function (mains voltage):
 - a short push to turn on and off;
 - a longer push to increase or decrease light intensity;
 - regulation automatically stops at minimum and maximum values;
 - for another on, regulation or off command, release the push button and give the desired command again;
 - **dimming level memory at mains restore.**
- Possibility to use PUSH function to 4/5 drivers without sync cable.
- Maximum length of the cable, from push button to last driver, must be max. 15 m / 49 ft. In case of applications where the cable is longer than 15 m / 49 ft, keep this separate from the 110 - 240 Volt mains cable.
- ATTENTION: only use normally open push buttons with no incorporated warning light.
- Short circuit 1...10V port for at least 5 sec to reset the device to ON/OFF & 0/1-10V modes.
- Specific dimming terminal connection with a 0/1...10 Vdc electronic potentiometer (0/1...10 V local dimming, double insulation required for external connection).

For additional details for regulations see pages info12-14.

Modalità di funzionamento

- Regolazione della luminosità 0/1 - 100 % mediante funzione PUSH, interfaccia locale 0/1...10 V (I=1 mA) o potenziometro da 100 Kohm.
 - **Regolazione solo AM: 1-100%.**
 - Regolazione della luminosità 0/1 - 100 % mediante la funzione PUSH (tensione di rete L; 170 Kohm):
 - una pressione breve per accendere e spegnere;
 - una pressione prolungata per aumentare o diminuire l'intensità luminosa;
 - la regolazione si ferma automaticamente ai valori minimi e massimi;
 - per un nuovo comando accensione, regolazione o spegnimento, rilasciare il pulsante e dare nuovamente il comando desiderato;
 - **ripristino del livello di dimming al ritorno alimentazione.**
 - Possibilità di utilizzo funzione PUSH fino a 4/5 alimentatori senza cavo di sincronismo.
 - La lunghezza massima dei cavi, dal pulsante all'ultimo trasformatore, deve essere max. 15 m / 49 ft. In caso di applicazioni dove il cavo superi i 15 m / 49 ft, tenere lo stesso separato dal cavo di rete 110 - 240 Volt.
 - ATTENZIONE: usare solo pulsanti di tipo normalmente aperto privi di spia luminosa incorporata.
 - Corto circuito porta 1...10V per almeno 5 sec per riportare il dispositivo alle modalità ON/OFF & 0/1-10V modes.
 - Provvisto di morsetto specifico per la regolazione collegando un potenziometro elettronico 0/1...10 Vdc (dimmerazione locale 0/1...10 V, per connessioni esterne all'apparecchio garantire il doppio isolamento).
- Per ulteriori dettagli sulle regolazioni vedi pagine info12-14.