



**Rated Voltage**  
**Tensione Nominale**  
 220 ÷ 240 V

**Frequency**  
**Frequenza**  
 50-60 Hz

**AC Operation range**  
**Tensione di utilizzo AC**  
 198 ÷ 264 V

**DC Operation range**  
**Tensione di utilizzo DC**  
 (see page info15)  
 176 ÷ 264 V  
 (NO 150 W)

**Power - Potenza**  
 0 ÷ 150 W

**iTHD**  
 ≤ 10% <sup>(1)</sup>

**Output current ripple**  
 ≤ 3% <sup>(1)</sup>

**Standards compliance**  
 EN 55015  
 EN 61000-3-2  
 EN 61000-3-3  
 EN 61347-1  
 EN 61347-2-13  
 EN 61547

**Max. pcs for CB B16A**  
 (see page info17)  
 15 pcs

**In rush current**  
 15A 600µsec

**Max. pcs for CB B16A**  
 (see page info17)  
 8 pcs (for DC 150W)

**In rush current**  
 35A 1000µsec  
 (for DC 150W)

Article Articolo	Code Codice	W	V out DC	I out DC	ta °C	tc °C	λ max. Power Factor	η max. Efficiency <sup>(1)</sup>
DC 70W 12V ST2	122477	70	12	5,80 A max.	-40...+45	70	0,97	> 89 %
DC 70W 24V ST2	122479	70	24	2,90 A max.	-40...+45	70	0,97	> 91 %
DC 70W 48V ST2	122481	70	48	1,45 A max.	-40...+45	70	0,97	> 91 %
DC 150W 24V ST2	122511	150	24	6,25 A max.	-40...+45	75	0,98	> 94 %
DC 150W 48V ST2 <sup>(2)</sup>	122513	150	48	3,12 A max.	-40...+45	75	0,98	> 94 %

<sup>(1)</sup> Referred to  $V_m = 230$  V, 100% load - Riferito a  $V_m = 230$  V, carico 100%

<sup>(2)</sup> Without ENEC / DEKRA - Senza ENEC / DEKRA

**Light output level in DC operation: Factory default 100% EOfu=1**

**Livello di emissione luminosa in funzionamento DC: Impostazioni di fabbrica 100% EOfu=1**

CASE **IP 67** SCREW FIXING Weight - Peso gr. 600 / 21,16 oz.  
 Pcs - Pezzi 15

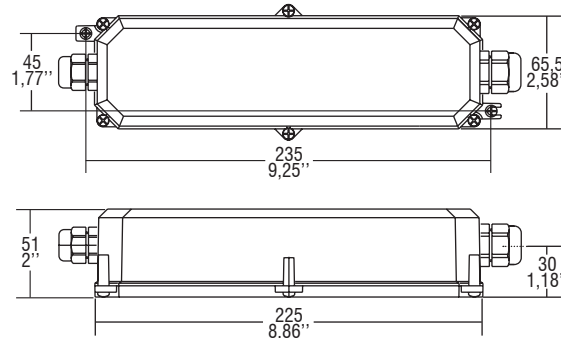

**Wiring diagram - Schema di collegamento**

(Max. LED distance at page info8 - Massima distanza LED a pagina info8)

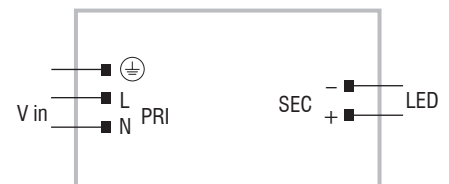

**Features**

- **Not dimmable driver.**
- Independent driver with IP67 case, for outdoor use (see page info7 for the correct connection of connecting leads).
- Class I protection against electric shock for direct or indirect contact.
- Supplied with connecting leads on primary and secondary circuits for connection.
- If the input cable is damaged it can only be replaced by authorized personnel.
- Driver can be secured with slot for screws.
- Protections:
  - against overheating and short circuits;
  - against mains voltage spikes;
  - against overloads.
- Conformal Coating available upon request.
- Thermal protection = C.5.a.

**Caratteristiche**

- **Alimentatore non regolabile.**
- Alimentatore indipendente con case IP67, per uso esterno (vedi pagina info7 per il corretto collegamento dei cavi di connessione).
- Protetto in classe I contro le scosse elettriche per contatti diretti e indiretti.
- Fornito di cavi di connessione su primario e secondario per il collegamento.
- Se il cavo di rete è danneggiato deve essere sostituito da personale autorizzato.
- Fissaggio dell'alimentatore tramite asole per viti.
- Protezioni:
  - termica e cortocircuito;
  - contro le extra-tensioni di rete;
  - contro i sovraccarichi.
- Tropicalizzazione disponibile su richiesta.
- Protezione termica = C.5.a.

