

# MAXI JOLLY HC 60 BLL



Direct current wireless dimmable electronic drivers with DIP-SWITCH  
Alimentatori elettronici wireless regolabili in corrente continua con DIP-SWITCH

Made in Italy

W.3

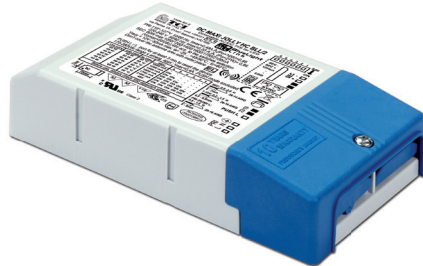

DC MAXI JOLLY HC BLL/2

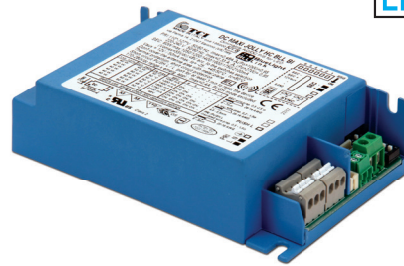

DC MAXI JOLLY HC BLL BI

Wireless systems components - BLL  
Componenti per sistemi wireless - BLL



**Rated Voltage**  
Tensione Nominale  
110 ÷ 120 V<sup>(2)</sup>  
220 ÷ 240 V

**Frequency**  
Frequenza  
50-60 Hz

**AC Operation range**  
Tensione di utilizzo AC  
100 ÷ 264 V

**DC Operation range**  
Tensione di utilizzo DC  
(see page info15)  
DC 170 ÷ 280 V  
(NO PUSH mode function)

**Power - Potenza**  
1 ÷ 60 W

**iTHD**  
≤ 10%<sup>(1)</sup>

**Output current ripple**  
≤ 3%<sup>(1)</sup>

**Standards compliance**  
EN 50172 (VDE 0108)  
EN 55015  
EN 60598-1  
EN 61000-3-2  
EN 61000-3-3  
EN 61347-1  
EN 61347-2-13  
EN 61547  
EN 62384  
EN 62311  
ETSI EN 300 328  
ETSI EN 301 489-1  
ETSI EN 301 489-17

**Max. pcs for CB B16A**  
(see page info17)  
30 pcs

**In rush current**  
10A 200μsec

Article Articolo	Code Codice	P out W	V out DC <sup>(1)</sup>	I out DC	U out V	ta °C	tc °C	λ Power Factor	η max. Efficiency <sup>(1)</sup>
DC MAXI JOLLY HC BLL/2 <sup>(4)</sup>	135001	45 (40 <sup>(2)</sup> )	2...44	1,05 A cost.	55	-25...+45 <sup>(4)</sup> /50	80	0,95 <sup>(3)</sup>	> 92
		52 (40 <sup>(2)</sup> )	2...44	1,2 A cost.					
DC MAXI JOLLY HC BLL BI	135000	55 <sup>(4)</sup> /60 (40 <sup>(2)</sup> )	2...43	1,4 A cost.	55	-25...+45	80	0,95 <sup>(3)</sup>	> 92
		55 <sup>(4)</sup> /60 (40 <sup>(2)</sup> )	2...38	1,6 A cost.					
		55 <sup>(4)</sup> /60 (40 <sup>(2)</sup> )	2...35	1,75 A cost.					
		55 <sup>(4)</sup> /60 (40 <sup>(2)</sup> )	2...29	2,1 A cost.					
48Vout voltage limit settable with Dip-Switch - Poutmax=55 <sup>(4)</sup> /60 W									

<sup>(1)</sup> Referred to V<sub>m</sub> = 230 V, 100% load - Riferito a V<sub>m</sub> = 230 V, carico 100%

<sup>(3)</sup> Pout > 35 W  
λ > 0,91 for Pout > 25 W

Optional versions with external antenna - Versioni opzionali con antenna esterna

**DC MAXI JOLLY HC BLL/2 EX - cod. 135013**

**DC MAXI JOLLY HC BLL BI EX - cod. 135011**

## Features

- Multipower driver supplied with dip-switch for the selection of the output current **with integrated wireless BLL module.**
- IP20 independent driver, for indoor use (DC MAXI JOLLY HC BLL/2).
- Class I protection against electric shock for direct or indirect contact (DC MAXI JOLLY HC BLL/2).
- Driver for built-in use (DC MAXI JOLLY HC BI BLL).
- It can be used for lighting equipment in protection class I.
- Active Power Factor Corrector.
- Auxiliary output 12 V max. 100 mA.
- Current regulation ±5 % including temperature variations.
- Input and output terminal blocks on the same side (wire cross-section up to 1,5 - 2,5 mm<sup>2</sup> / AWG15 - AWG13).
- Clamping screws on primary and secondary circuits for cables with diameter: min. 3 - max. 8 mm (DC MAXI JOLLY HC BLL/2).
- Protections:
  - against overheating and short circuits;
  - against mains voltage spikes;
  - against overloads.
- Thermal protection = C.5.a.

## Caratteristiche

- Alimentatore multipotenza fornito di dip-switch per la selezione della corrente in uscita **con integrato modulo wireless BLL.**
- Alimentatore indipendente IP20, per uso interno (DC MAXI JOLLY HC BLL/2).
- Protetto in classe I contro le scosse elettriche per contatti diretti e indiretti (DC MAXI JOLLY HC BLL/2).
- Alimentatore da incorporare (DC MAXI JOLLY HC BI BLL).
- Utilizzabile per apparecchi di illuminazione in classe di protezione I.
- PFC attivo.
- Uscita ausiliare 12 V max. 100 mA.
- Corrente regolata ±5 % incluse variazioni di temperatura.
- Morsetti di entrata e uscita sullo stesso lato (sezione cavo fino a 1,5 - 2,5 mm<sup>2</sup> / AWG15 - AWG13).
- Serracavo su primario e secondario per cavi di diametro: min. 3 mm - max. 8 mm (DC MAXI JOLLY HC BLL/2).
- Protezioni:
  - termica e cortocircuito;
  - contro le extra-tensioni di rete;
  - contro i sovraccarichi.
- Protezione termica = C.5.a.

Accessories not supplied - Accessori non a corredo		
Article - Articolo	L (length)	Code - Codice
Synchronization cable Cavetto di sincronizzazione	1,5 m / 4 ft	485720512
	4 m / 13 ft	485720513
	50 cm / 19,68"	485720515
20 cm / 7,87"	485720516	
6 pin cable for LED and AUX Cavo 6 poli per LED e AUX	50 cm / 19,68"	425720017



## Direct current wireless dimmable electronic drivers with DIP-SWITCH Alimentatori elettronici wireless regolabili in corrente continua con DIP-SWITCH

Made in Italy



**IP 20** **SCREW FIXING** Ø90 3,54" Weight - Peso gr. 235 / 8,3 oz.  
Pcs - Pezzi 40

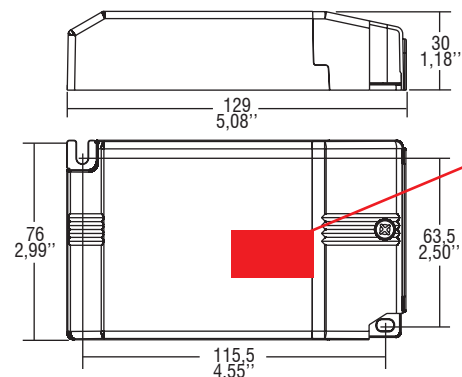

WIRELESS ANTENNA  
KEEP CLEAR THIS AREA

**BUILT-IN** **SCREW FIXING** Weight - Peso gr. 230 / 8,1 oz.  
Pcs - Pezzi 40  
Compatible with ZHAGA (AM2)

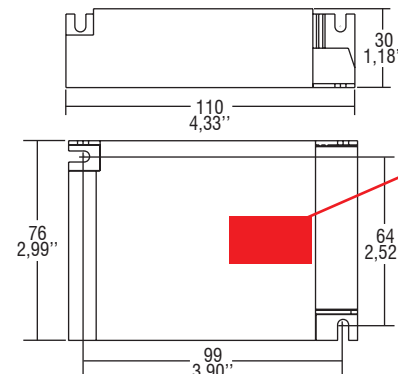

WIRELESS ANTENNA  
KEEP CLEAR THIS AREA

Wireless systems components - BLL  
Componenti per sistemi wireless - BLL

W.3

### Wiring diagram - Schema di collegamento (Max. LED distance on page info8 - Massima distanza LED a pagina info8)

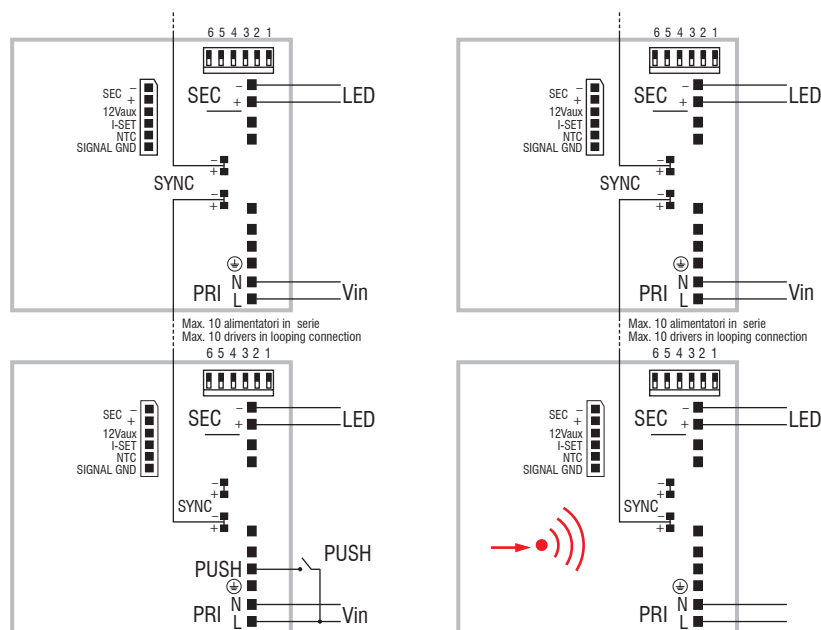

PUSH diagram - Collegamento PUSH

BLL diagram - Collegamento BLL



To be used through APP available on Apple Store and Play Store for iOS and Android.  
Utilizzabile tramite APP disponibile su Apple Store e Play Store per sistemi iOS e Android.

### Operation Mode

- Light regulation 0/0,5 - 100 % by means of PUSH function and **APP or compatible devices for BLL integrated WIRELESS module.**
- Features of regulation through PUSH function:
  - a short push to turn on and off;
  - a longer push to increase or decrease light intensity;
  - regulation automatically stops at minimum and maximum values;
  - for another on, regulation or off command, release the push button and give the desired command again;
  - dimming level memory at mains restore;
  - start/stop plays of light.
- **Features of remote control by APP:**
  - turn on and turn off;
  - setup and control of groups;
  - choice among pre-set scenarios;
  - creation of scenarios.
- Possibility to use PUSH function to 4/5 drivers without sync cable.
- Maximum length of the cable, from push button to last driver, must be max. 15 m / 49 ft. In case of applications where the cable is longer than 15 m / 49 ft, keep this separate from the 240 V mains cable.
- **ATTENTION:** only use normally open push buttons with no incorporated warning light.
- Max. 10 synchronised drivers of which only one can be controlled (1 Master + 9 Slaves).
- Synchronization cable is separately supplied.

### Modalità di funzionamento

- Regolazione della luminosità 0/0,5 - 100 % mediante funzione PUSH e **APP o dispositivi compatibili per modulo WIRELESS BLL integrato.**
- Caratteristiche della regolazione mediante PUSH:
  - una pressione breve per accendere e spegnere;
  - una pressione prolungata per aumentare o diminuire l'intensità luminosa;
  - la regolazione si ferma automaticamente ai valori minimi e massimi;
  - per un nuovo comando accensione, regolazione o spegnimento, rilasciare il pulsante e dare nuovamente il comando desiderato;
  - ripristino del livello di dimming al ritorno alimentazione;
  - avvio/stop giochi di luce.
- **Caratteristiche della regolazione mediante APP:**
  - accensione e spegnimento;
  - creazione e controllo di gruppi;
  - scelta tra scenari preconfigurati;
  - creazione di scenari.
- Possibilità di utilizzo funzione PUSH fino a 4/5 alimentatori senza cavo di sincronismo.
- La lunghezza massima del cavo, dal pulsante all'ultimo trasformatore, deve essere max. 15 m / 49 ft. In caso di applicazioni dove il cavo supera i 15 m / 49 ft, tenere lo stesso separato dal cavo di rete 240 V.
- **ATTENZIONE:** usare solo pulsanti di tipo normalmente aperto privi di spia luminosa incorporata.
- Max. 10 alimentatori sincronizzati, di cui uno solo comandato da uno o più punti (1 Master + 9 Slaves).
- Cavetto per la sincronizzazione fornito separatamente.

Check signal level when close to metal surfaces or inside metal box - Verificare livello del segnale in presenza di superfici o box di metallo