

SIRIO 150/1050 ST2

IP67 direct current electronic drivers
Alimentatori elettronici in corrente continua IP67

Made in Italy

constant
CURRENT



RIPPLE FREE

Pst LM ≤ 1
SVM $\leq 0,4$



Rated Voltage
Tensione Nominale
220 ÷ 240 V

Frequency
Frequenza
50-60 Hz

AC Operation range
Tensione di utilizzo AC
198 ÷ 264 V

Power - Potenza
74 ÷ 150 W

iTHD
 $\leq 15\%$ ⁽¹⁾

Output current ripple
 $\leq 3\%$ ⁽¹⁾

Standards compliance
EN 55015
EN 61000-3-2
EN 61000-3-3
EN 61347-1
EN 61347-2-13
EN 61547

Max. pcs for CB B16A
(see page info17)
8 pcs

In rush current
35A 1000 μ sec

Article Articolo	Code Codice	P out W	V out DC	I out DC	U out V	ta °C	tc °C	λ max. Power Factor	η max. Efficiency ⁽¹⁾
SIRIO 150/1050 ST2	127295	150	70...142 V	1,05 A cost.	280	-40...+45	75	0,95	> 94 %

⁽¹⁾ Referred to $V_m = 230$ V, 100% load - Riferito a $V_m = 230$ V, carico 100%

IP 67 **SCREW FIXING** Weight - Peso gr. 615 / 21,7 oz.
Pcs - Pezzi 15

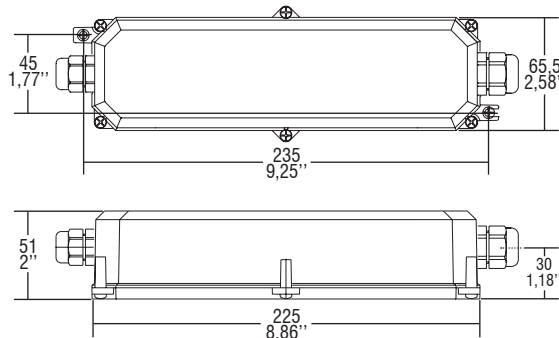

Wiring diagrams - Schemi di collegamento
(Max. LED distance at page info8 - Massima distanza LED a pagina info8)

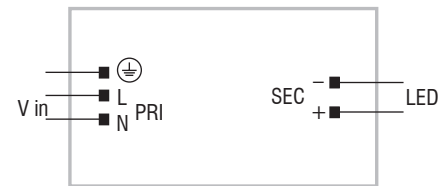

Features

- Independent driver with case IP67 (see page info7 for the correct connection of connecting leads).
- Class I protection against electric shock for direct or indirect contact.
- Active Power Factor Corrector.
- Current regulation $\pm 5\%$ including temperature variations.
- Supplied with connecting leads on primary (0,5 m / 1,64 ft.) and secondary (1 m / 3,28 ft.) circuits for connection.
- If the input cable is damaged it can only be replaced by authorized personnel.
- Driver can be secured with slot for screws.
- Protections:
 - against overheating and short circuits;
 - against mains voltage spikes;
 - against overloads.
- Thermal protection = C.5.a.
- Conformal Coating available upon request.

Caratteristiche

- Alimentatore indipendente con case IP67 (vedi pagina info7 per il corretto collegamento dei cavi di connessione).
- Protetto in classe I contro le scosse elettriche per contatti diretti e indiretti.
- PFC attivo.
- Corrente regolata $\pm 5\%$ incluse variazioni di temperatura.
- Fornito di cavi di connessione su primario (0,5 m / 1,64 ft.) e secondario (1 m / 3,28 ft.) per il collegamento.
- Se il cavo di rete è danneggiato deve essere sostituito da personale autorizzato.
- Fissaggio dell'alimentatore tramite asole per viti.
- Protezioni:
 - termica e cortocircuito;
 - contro le extra-tensioni di rete;
 - contro i sovraccarichi.
- Protezione termica = C.5.a.
- Tropicalizzazione disponibile su richiesta.

7 YEARS WARRANTY
3% FAILURE RATE

10 YEARS WARRANTY
5% FAILURE RATE



4.1

Street lighting and high power drivers - Not dimmable multipower DIP-SWITCH
Alimentatori per illuminazione stradale e alta potenza - Non regolabili multipotenza con DIP-SWITCH