

Direct current dimmable electronic drivers with DIP-SWITCH

Alimentatori elettronici regolabili in corrente continua con DIP-SWITCH



3.1.2

Dimmable multipower drivers - Compact case - DALI
Alimentatori multipotenza regolabili - Formato compatto - DALI

Rated Voltage
Tensione Nominale
220 ÷ 240 V

Frequency
Frequenza
50-60 Hz

AC Operation range
Tensione di utilizzo AC
198 ÷ 264 V

Power - Potenza
2 ÷ 44 W

iTHD
≤ 10% ⁽¹⁾

Stand by power
≤ 0,5 W

Output current ripple
≤ 5% ⁽¹⁾

Standards compliance
EN 55015
EN 61000-3-2
EN 61347-1
EN 61347-2-13
EN 61547
EN 62384
EN 62386-101
EN 62386-102
EN 62386-207

Max. pcs for CB B16A
(see page info17)
50 pcs

In rush current

14W: 15A 244μsec
17W: 15A 246μsec
25W: 15A 250μsec
33W: 20A 266μsec
40W: 23A 260μsec
44W: 18A 275μsec



Article Articolo	Code Codice	P out W	V out DC	I out DC	U out V	ta °C	tc °C	λ max. Power Factor	η max. Efficiency ⁽¹⁾
PROFESSIONALE DALI ECO 14W	145160	7	6...20	350 mA cost.	59	-20... +45	75	0,95 Pout > 14 W	> 83 %
		10	6...20	500 mA cost.					
		11	6...20	550 mA cost.					
		14	6...20	700 mA cost.					
PROFESSIONALE DALI ECO 17W	145161	10,5	20...42	250 mA cost.	59	-20... +45	70	0,95 Pout > 17 W	> 87 %
		12,6	20...42	300 mA cost.					
		14,7	20...42	350 mA cost.					
PROFESSIONALE DALI ECO 25W	145162	18,9	20...42	450 mA cost.	59	-20... +45	80	0,95 Pout > 25 W	> 88 %
		21	20...42	500 mA cost.					
		23,1	20...42	550 mA cost.					
		25,2	20...42	600 mA cost.					
PROFESSIONALE DALI ECO 33W	145163	27,3	20...42	650 mA cost.	59	-20... +45	80	0,95 Pout > 33 W	> 89 %
		29,4	20...42	700 mA cost.					
		31,5	20...42	750 mA cost.					
		33,6	20...42	800 mA cost.					
PROFESSIONALE DALI ECO 40W	145165	25	30...50	500 mA cost.	59	-20... +45	80	0,95 Pout > 40 W	> 89 %
		30	30...50	600 mA cost.					
		35	30...50	700 mA cost.					
		40	30...50	800 mA cost.					
PROFESSIONALE DALI ECO 44W	145164	37,8	20...42	850 mA cost.	59	-20... +45	80	0,95 Pout > 44 W	> 89 %
		39,9	20...42	900 mA cost.					
		42	20...42	950 mA cost.					
		44,1	20...42	1050 mA cost.					

⁽¹⁾ Referred to $V_m = 230$ V, 100% load - Riferito a $V_m = 230$ V, carico 100%

Features

- Multipower driver supplied with dip-switch for the selection of the output current.
- Current regulation ± 5 % including temperature variations.
- Driver for built-in use.
- It can be used for lighting equipment in protection class I and II.
- ⁽²⁾⁽³⁾ IP20 class II independent driver (only with optional strain reliefs), for indoor use.
- Input and output terminal blocks on opposite sides (wire cross-section up to 1,5 mm² / AWG15).
- ⁽²⁾ Clamping screws on primary and secondary circuits for cables with diameter: min. 3 mm - max. 7 mm.
- ⁽³⁾ Clamping screws on primary and secondary circuits for cables with diameter: min. 5 mm - max. 12 mm. Double input and DALI terminal blocks to loop other driver.
- Driver can be secured with slot for screws.
- Protezioni:
 - short circuits;
 - against mains voltage spikes;
 - against overloads.

Caratteristiche

- Alimentatore multipotenza fornito di dip-switch per la selezione della corrente in uscita.
- Corrente regolata ± 5 % incluse variazioni di temperatura.
- Alimentatore da incorporare.
- Utilizzabile per apparecchi di illuminazione in classe di protezione I e II.
- ⁽²⁾⁽³⁾ Alimentatore indipendente IP20 classe II (solo con coperchietti opzionali), per uso interno.
- Morsetti di entrata e uscita contrapposti (sezione cavo fino a 1,5 mm² / AWG15).
- ⁽²⁾ Serracavo su primario e secondario per cavi di diametro: min. 3 mm - max. 7mm.
- ⁽³⁾ Serracavo su primario e secondario per cavi di diametro: min. 5 mm - max. 12 mm. Doppia morsettiera lato rete e DALI per rimando ad altro alimentatore.
- Fissaggio dell'alimentatore tramite asole per viti.
- Protezioni:
 - cortocircuito;
 - contro le extra-tensioni di rete;
 - contro i sovraccarichi.

The data shown are preliminary and may change - I dati riportati sono preliminari e potrebbero subire variazioni

Direct current dimmable electronic drivers with DIP-SWITCH Alimentatori elettronici regolabili in corrente continua con DIP-SWITCH



⁽²⁾ ONLY WITH OPTIONAL STRAIN RELIEF (488787805)
SOLO CON COPERCHIETTO OPZIONALE (488787805)

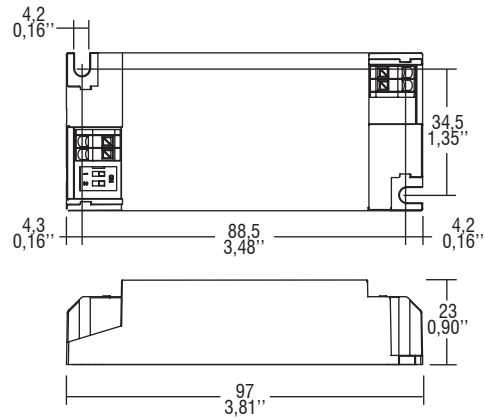
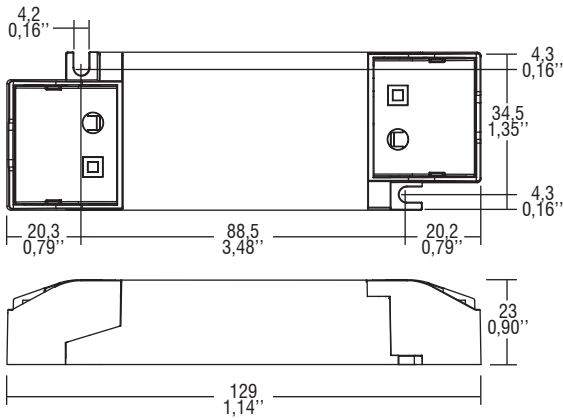

⁽³⁾ ONLY WITH OPTIONAL STRAIN RELIEF (488787807)
SOLO CON COPERCHIETTO OPZIONALE (488787807)

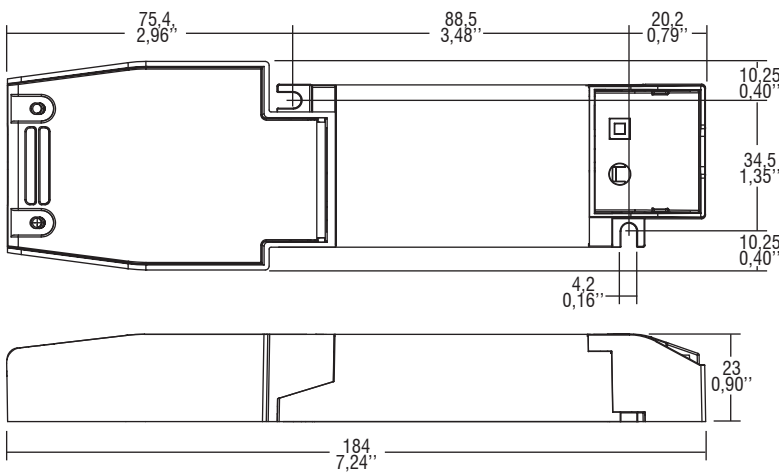

Wiring diagram - Schema di collegamento

(Max. LED distance on page info8 - Massima distanza LED a pagina info8)

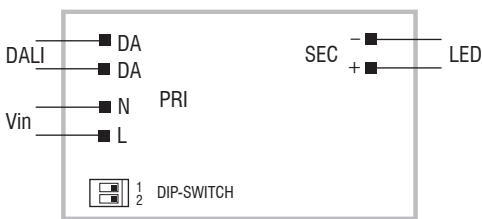

DALI diagram
Collegamento DALI

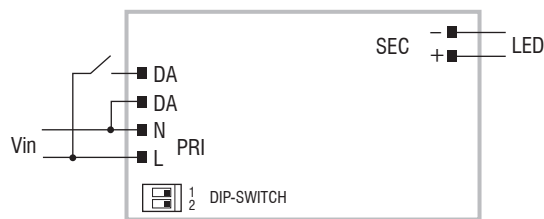

PUSH SWITCH diagram
Collegamento PUSH SWITCH

Operation Mode

- Features DALI dimming (0/1 - 100 %; 10mA minimum current):
 - memory function for sets or light groups;
 - recall of stored functions;
 - compatible with standard DALI interfaces.
- **Dimming method is AMPLITUDE.**
- Light regulation 0/1 - 100 % by means of PUSH SWITCH function (mains voltage):
 - a short push to turn on and off;
 - a longer push to increase or decrease light intensity;
 - regulation automatically stops at minimum and maximum values;
 - for another on, regulation or off command, release the push button and give the desired command again;
 - dimming level memory at mains restore.

For additional details for regulations see pages info12-14.

Modalità di funzionamento

- Caratteristiche della regolazione DALI (0/1 - 100 %; corrente minima 10mA):
 - funzione di memoria per scenari o gruppi luminosi;
 - richiamo di funzioni memorizzate;
 - compatibilità con interfacce DALI standard.
 - **La dimmerazione è in ampiezza.**
 - Regolazione della luminosità 0/1 - 100 % mediante la funzione PUSH SWITCH (tensione di rete):
 - una pressione breve per accendere e spegnere;
 - una pressione prolungata per aumentare o diminuire l'intensità luminosa;
 - la regolazione si ferma automaticamente ai valori minimi e massimi;
 - per un nuovo comando accensione, regolazione o spegnimento, rilasciare il pulsante e dare nuovamente il comando desiderato;
 - ripristino del livello di dimming al ritorno alimentazione.
- Per ulteriori dettagli sulle regolazioni vedi pagine info12-14.

3.1.2

Dimmable multipower drivers - Compact case - DALI
Alimentatori multipotenza regolabili - Formato compatto - DALI